

KM



Ventilatore centrifugo direttamente accoppiato. Prodotto in acciaio al carbonio protetto dalla corrosione tramite verniciatura per cataforesi con smalto poliuretano bicomponente RAL 7045.

#### Esecuzioni standard

- Esecuzione 4: Accoppiamento diretto. Girante calettata direttamente sull'albero del motore B3 che è sostenuto dalla sedia. Temperatura massima dell'aria 100°C. Con ventolina di raffreddamento fino a 220°C.
- Esecuzione 5: Accoppiamento diretto. Girante calettata direttamente sull'albero del Motore B5 sostenuto da un disco fissato sul fianco cassa.
- Esecuzione 8: Accoppiamento a giunto. Girante calettata a sbalzo. Supporto e motore montati su sedia fuori dal circuito dell'aria. Temperatura massima dell'aria 100°C. Con ventolina di raffreddamento fino a 300°C.

#### Motori

Motori standard da 2, 4 poli ad alta efficienza con alimentazione trifase 230/400V 50Hz fino alla taglia 112 e 400/690V 50Hz per le taglie superiori. Grado di protezione IP55, classe F.

#### Su richiesta

- Progettazione speciale con diversi materiali costruttivi.
- Versione a 60Hz.
- Verniciatura con RAL diversi dallo standard.
- Parti statiche del ventilatore zincate a caldo.

- Soluzioni con materiali resistenti alla corrosione.
- Versione con materiali antiusura.
- Motori elettrici per applicazioni speciali.
- Motori elettrici adatti per VSD.
- Possibilità di configurazione con svariati accessori tra cui: Giunti antivibranti, portello d'ispezione, tappo di scarico, ammortizzatori, reti di protezione, filtro, silenziatore, regolatore di portata, valvole e serrande.
- Coibentazione.

#### Versioni ATEX

Su richiesta ventilatori installati in luogo con pericolo di esplosione conformi alla direttiva 2014/34/UE (ATEX):

Temperatura ambiente tra -20°C/+60°C, pressione ambiente (assoluta) tra 0,8bar/1,1bar, in accordo con EN 14986.

- Gas:
  - ⊗ 3G IIB T2-T3-T4
  - ⊗ 3G IIB+H2 T2-T3-T4
- Polvere non conduttiva:
  - ⊗ 2D\* IIB T125°C-T135°C-T195°C-T295°C
  - ⊗ 3D IIB T125°C-T135°C-T195°C-T295°C
- Polvere conduttiva (con motore IP65 IIIC):
  - ⊗ 2D\* IIIC T125°C-T135°C-T195°C-T295°C
  - ⊗ 3D IIIC T125°C-T135°C-T195°C-T295°C

\* Solo se è previsto per il trasporto di fibre di cellulosa tritate.

*Direct drive, single inlet centrifugal fan. Manufactured from steel sheet protected with cataforesis primer + polyurethane paint finish RAL 7045.*

#### Standard arrangement

- Arrangement 4: Direct drive. Impeller directly mounted on motor shaft. B3 motor is supported by the pedestal. Max air temperature 100°C. With cooling disk up to 220°C.
- Arrangement 5: Direct drive. Impeller directly mounted on motor shaft. B5 motor is fitted on casing sideplate.
- Arrangement 8: Flexible coupling. Overhung impeller. Support and motor mounted on a base outside the air stream. Max air temperature 100°C. With cooling disk up to 300°C.

#### Motors

2 or 4 pole, high efficiency, three-phase 230/400V 50Hz up to motor size 112 and 400/690V 50Hz for higher motors. IP55, Class F protection.

#### On request

- Manufactured from different materials.
- 60 Hz versions.
- Painted in different RAL colour.
- Hot dip galvanized static parts.
- Corrosion proof construction.

- Wear proof construction.
- Motors for special applications.
- Motors suitable for VSD.
- Accessories: Flexible joints, inspection door, casing drain, AV-mounts, protection nets, filter, silencer, inlet discharge governor, valves, dampers.
- Gas tight construction.
- Thermal insulation.

#### ATEX versions

On request, explosion proof version fans in accordance with 2014/34/UE (ATEX directive):

Ambient temperature -20°C to +60°C, ambient pressure (abs.) 0,8 bar to 1,1 bar according to EN 14986.

- Gas:
  - ⊗ 3G IIB T2-T3-T4
  - ⊗ 3G IIB+H2 T2-T3-T4
- Non-conductive dust:
  - ⊗ 2D\* IIB T125°C-T135°C-T195°C-T295°C
  - ⊗ 3D IIB T125°C-T135°C-T195°C-T295°C
- Conductive dust (compulsory IP65 IIIC motor):
  - ⊗ 2D\* IIIC T125°C-T135°C-T195°C-T295°C
  - ⊗ 3D IIIC T125°C-T135°C-T195°C-T295°C

\* Only for fluff transport application.



Girante con pale aperte positive per trasporto materiale  
Forward blades impeller for material transport

#### QUADRO DI APPLICAZIONE TABLE OF APPLICATIONS

Tipologia del fluido Air Type	Quantità di polvere Dust quantity (mg/m <sup>3</sup> )
Trasporto di materiale pneumatico Conveying material and pneumatic transport	< 50000



**GIRANTE CON PALE RADIALI APERTE PER IL TRASPORTO PNEUMATICO - ACCOPIAMENTO DIRETTO**  
**RADIAL IMPELLER FOR MATERIAL TRANSPORT - DIRECT DRIVE**

**CARATTERISTICHE TECNICHE / TECHNICAL FEATURES**

È essenziale verificare che le caratteristiche elettriche (tensione, intensità, frequenza, ecc.) di targa del motore siano compatibili con l'impianto elettrico di installazione.

Please, check that electrical features (voltage, current, frequency, etc.) are suitable with your installation.

Modello Model	Taglia motore Motor size	Velocità Speed (r.p.m.)	Potenza motore Motor power (kW)	Intensità di corrente massima assorbita 400V Maximum absorbed current 400V (A)	Portata massima Maximum airflow (m <sup>3</sup> /h)	Pressione sonora a 1m Sound pressure level at 1 m (dB(A)) <sup>(1)</sup>	Peso Weight (kg) <sup>(2)</sup>	Momento di inerzia Moment of inertia (kg·m <sup>2</sup> ) <sup>(3)</sup>
2 POLI / 2 POLE								
KM 221/2 R4A	71A2	2810	0,37	0,90	1.080	68	18	0,01
KM 252/2 R4A	71B2	2820	0,55	1,25	1.080	70	25	0,02
KM 251/2 R4A	80A2	2830	0,75	1,59	1.470	71	28	0,02
KM 282/2 R4A	80B2	2840	1,10	2,33	1.510	73	32	0,03
KM 281/2 R4A	90S2	2840	1,50	3,07	2.070	74	36	0,04
KM 312/2 R4A	90S2	2840	1,50	3,07	2.160	77	42	0,05
KM 311/2 R4A	90L2	2850	2,20	4,43	2.930	78	45	0,06
KM 352/2 R4A	100LA2	2900	3,00	5,77	3.060	80	74	0,09
KM 351/2 R4A	112M2	2920	4,00	7,50	4.320	81	79	0,11
KM 402/2 R4A	132SA2	2890	5,50	10,10	4.250	84	107	0,16
KM 401/2 R4A	132SB2	2890	7,50	13,90	7.270	85	113	0,20
KM 452/2 R4A	132MB2	2900	9,20	16,60	6.120	87	140	0,30
KM 451/2 R4A	160MR2	2930	15,00	25,40	11.040	88	195	0,38
4 POLI / 4 POLE								
KM 452/4 R4A	90S4	1390	1,10	2,30	2.930	68	98	0,35
KM 451/4 R4A	90L4	1420	1,50	3,15	5.350	69	105	0,35
KM 502/4 R4A	100LA4	1420	2,20	4,56	4.250	72	124	0,55
KM 501/4 R4A	100LB4	1430	3,00	6,15	6.900	73	132	0,65
KM 562/4 R4A	112M4	1425	4,00	8,20	6.120	75	145	0,88
KM 561/4 R4A	132SA4	1440	5,50	10,30	9.840	76	170	1,08
KM 632/4 R4A	132MA4	1450	7,50	13,90	8.500	79	197	1,45
KM 631/4 R4A	160M4	1450	11,00	20,70	14.090	80	270	1,78
KM 712/4 R4A	160M4	1450	11,00	20,70	12.060	83	335	2,58
KM 711/4 R4A	160L4	1450	15,00	28,40	20.230	84	365	3,13
KM 802/4 R4A	180M4	1460	18,50	34,90	17.100	86	440	4,60
KM 801/4 R4A	200L4	1470	30,00	54,60	29.440	88	505	5,60
KM 902/4 R4A	225S4	1475	37,00	65,60	24.120	91	595	8,10
KM 901/4 R4A	225M4	1475	45,00	79,40	43.450	92	635	10,00
KM 1002/4 R4A	250M4	1475	55,00	96,90	34.200	95	800	14,00
KM 1001/4 R4A	280R4	1475	75,00	130,00	60.300	96	915	16,80

<sup>1</sup> Misurata in premente / Measured with duct on discharge

Tolleranza di +3dB(A), misurata nel massimo punto di efficienza / Noise level tolerance +3 dB(A), measured in the maximum efficiency point

<sup>2</sup> Con motore incluso e per gli orientamenti LG270 o RD270 / With motor included and for LG270 or RD270 position

<sup>3</sup> Momento di inerzia della girante / Impeller's moment of inertia

**CURVA CARATTERISTICA (in premente) / PERFORMANCE CURVES (at outlet)**

- Test effettuati con ventilatore canalizzato sia in aspirante che in premente.
- Portata in m<sup>3</sup>/h.
- **Psf: Pressione statica in Pa.**
- Modello - Potenza del motore in kW.
- Esempio: 401 - 7,5  
Modello - kW

- Fan ducted on both inlet and outlet sides.
- Air volume in m<sup>3</sup>/h.
- **Psf: Static pressure in Pa.**
- Model - Motor power in kW.
- Example: 401 - 7,5  
Model - kW

2 poli - Modelli dal 221 al 451  
2 pole - Models from 221 to 451

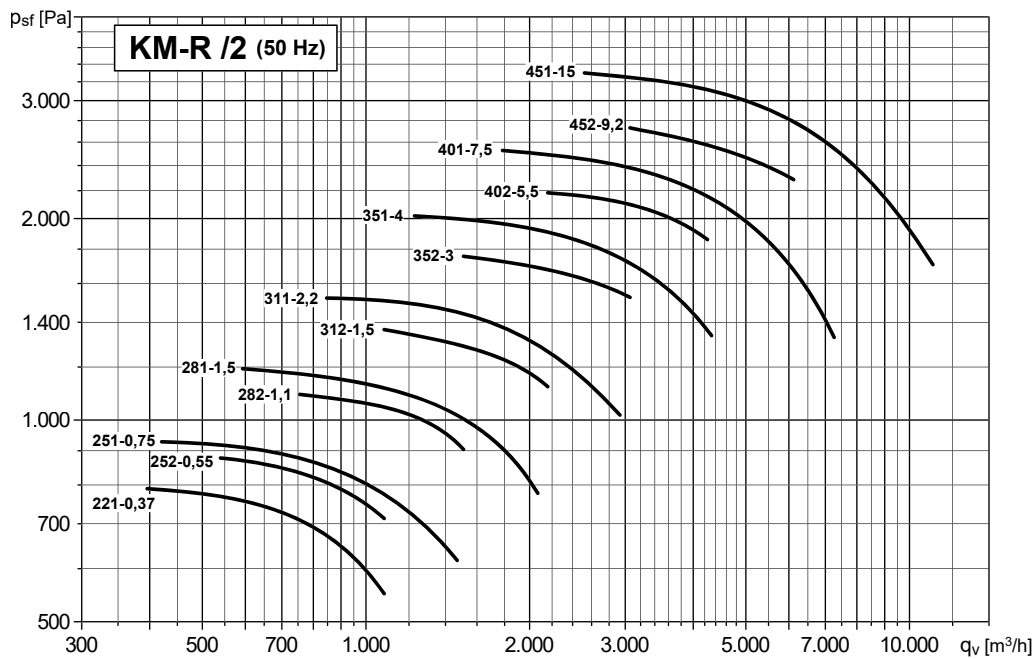

4 poli - Modelli dal 452 al 631  
4 pole - Models from 452 to 631

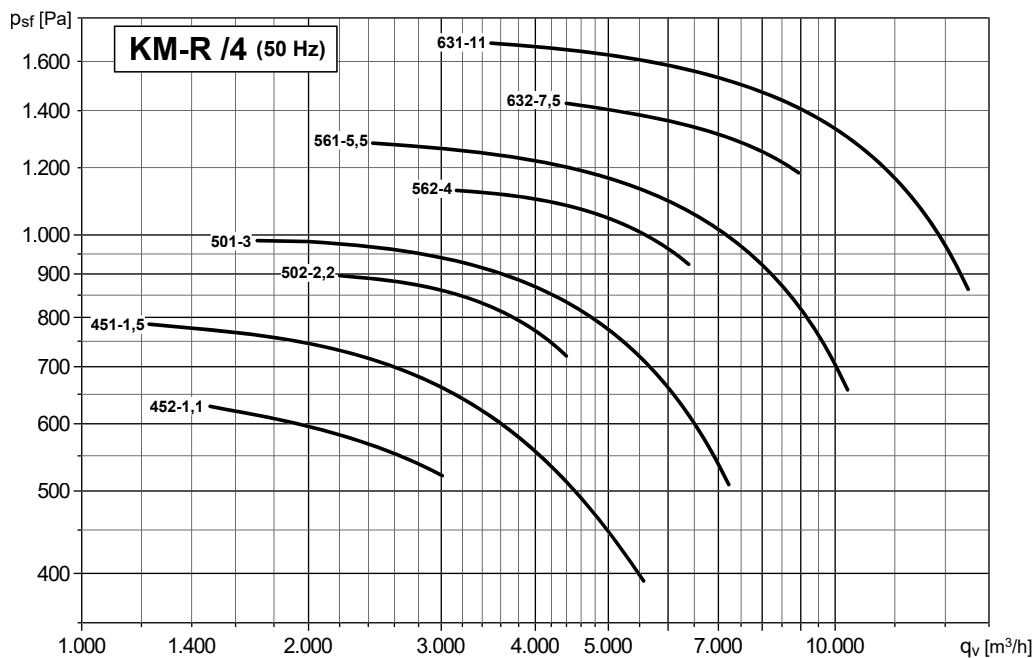

GIRANTE CON PALE RADIALI APERTE PER IL TRASPORTO PNEUMATICO - ACCOPIAMENTO DIRETTO  
*RADIAL IMPELLER FOR MATERIAL TRANSPORT - DIRECT DRIVE*



**CURVA CARATTERISTICA (in premente) / PERFORMANCE CURVES (at outlet)**

- Test effettuati con ventilatore canalizzato sia in aspirante che in premente.
- Portata in m<sup>3</sup>/h.
- **Psf: Pressione statica in Pa.**
- Modello - Potenza del motore in kW.
- Esempio: 401 - 7,5  
Modello - kW
- Fan ducted on both inlet and outlet sides.
- Air volume in m<sup>3</sup>/h.
- **Psf: Static pressure in Pa.**
- Model - Motor power in kW.
- Example: 401 - 7,5  
Model - kW

4 poli - Modelli dal 712 al 1001  
 4 pole - Models from 712 to 1001



**GIRANTE CON PALE RADIALI APERTE PER IL TRASPORTO PNEUMATICO - ACCOPIAMENTO DIRETTO**  
**RADIAL IMPELLER FOR MATERIAL TRANSPORT - DIRECT DRIVE**

**DIMENSIONI (mm) (modelli dal 221 al 501) / DIMENSIONS (mm) (models from 221 to 501)**

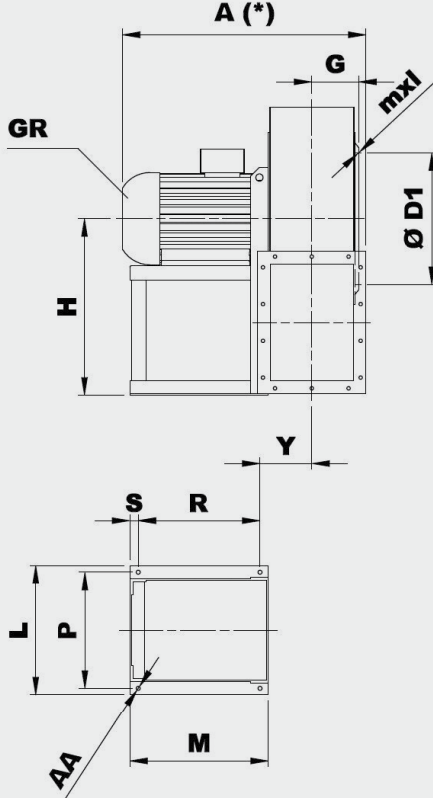

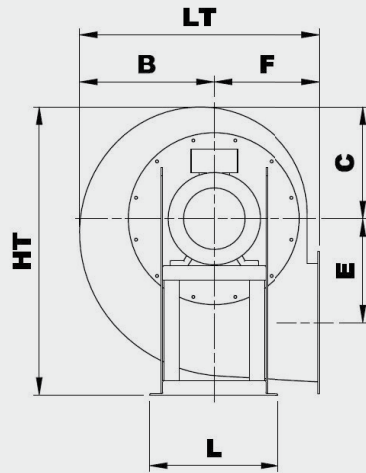







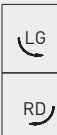



CASSA ORIENTABILE  
ADJUSTABLE CASING

**ORIENTAMENTI / POSITIONS**

	0°	45°	90°	135°	180°	225°	270°	315°
								
	H1			H2			H3	

Per ventilatori con orientamenti 180° e 225° richiedere fattibilità  
 For fans with 180° and 225° positions, please request feasibility

Tipo Type		Ventilatore Fan											Base Base					Esecuzione 4B <sup>(1)</sup> Arrangement 4B <sup>(1)</sup>							
Ventilatore Fan	Motore GR Motor GR	A*	B	C	Ø D1	E	F	G	H			HT	LT	mxl	Y	L	P	M	R	S	Ø AA	A*	Y	R	M
									H1	H2	H3														
KM 221/2 R4A	71A2	350	220	195	165	176	180	63	300	180	300	495	400	M6X16	100	225	203	215	156	14	10	389	100	156	215
KM 251/2 R4A	80A2	410	245	210	219	176	195	79	315	195	315	525	440	M6X16	121	225	203	225	166	14	10	455	121	166	225
KM 252/2 R4A	71B2	380	245	210	219	176	195	79	315	195	315	525	440	M6X16	121	225	203	215	156	14	10	417	121	156	215
KM 281/2 R4A	90S2	440	270	235	241	202	200	88	375	200	375	610	470	M6X16	145	260	234	260	183	17	10	485	145	183	260
KM 282/2 R4A	80B2	420	270	235	241	202	200	88	375	200	375	610	470	M6X16	130	225	203	225	166	14	10	465	130	166	225
KM 311/2 R4A	90L2	480	300	260	265	230	225	99	400	225	400	660	525	M6X16	155	260	234	260	183	17	10	525	155	183	260
KM 312/2 R4A	90S2	450	300	260	265	230	225	99	400	225	400	660	525	M6X16	155	260	234	260	183	17	10	495	155	183	260
KM 351/2 R4A	112M2	530	340	295	292	253	255	110	450	255	450	745	595	M8X20	129	324	289	310	264	23	12	575	129	264	310
KM 352/2 R4A	100LA2	520	340	295	292	253	255	110	450	255	450	745	595	M8X20	129	324	289	295	249	23	12	565	129	249	295
KM 401/2 R4A	132SB2	630	375	330	332	286	285	122	500	285	500	830	660	M8X20	141	372	337	360	314	23	12	685	141	314	360
KM 402/2 R4A	132SA2	630	375	330	332	286	285	122	500	285	500	830	660	M8X20	141	372	337	360	314	23	12	685	141	314	360
KM 451/2 R4A	160MR2	760	425	370	366	321	320	138	560	320	560	930	745	M8X20	160	440	395	470	414	28	14	815	160	414	470
KM 451/4 R4A	90L4	550	425	370	366	321	320	138	560	320	560	930	745	M8X20	192	260	234	260	183	17	10	595	192	183	260
KM 452/2 R4A	132MB2	695	425	370	366	321	320	138	560	320	560	930	745	M8X20	156	372	337	360	314	23	12	750	156	314	360
KM 452/4 R4A	90S4	520	425	370	366	321	320	138	560	320	560	930	745	M8X20	192	260	234	260	183	17	10	565	192	183	260
KM 501/4 R4A	100LB4	650	470	410	405	354	360	159	600	360	600	1010	830	M8X20	171	324	289	295	249	23	12	695	171	249	295
KM 502/4 R4A	100LA4	650	470	410	405	354	360	159	600	360	600	1010	830	M8X20	171	324	289	295	249	23	12	695	171	249	295

<sup>1</sup> Con ventolina di raffreddamento / With cooling impeller  
 \* In relazione al tipo di motore / Depending on motor type

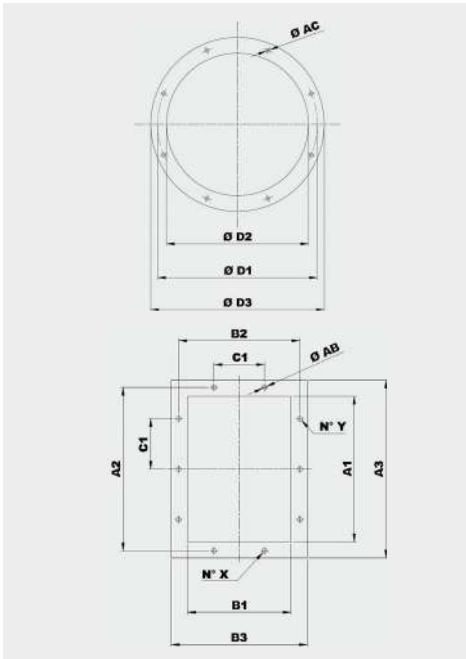
**GIRANTE CON PALE RADIALI APERTE PER IL TRASPORTO PNEUMATICO - ACCOPIAMENTO DIRETTO**  
**RADIAL IMPELLER FOR MATERIAL TRANSPORT - DIRECT DRIVE**

Modello Model	Flangia aspirante Inlet flange					
	Tipo di flangia Flange type	Ø D1	Ø D2	Ø D3	Ø AC	Fori Holes
221	125	165	129	189	8	4
251	180	219	184	254	8	8
281	200	241	204	274	8	8
311	224	265	228	298	8	8
351	250	292	254	324	10	8
401	280	332	285	365	10	8
451	315	366	320	400	10	8
501	355	405	360	440	10	8

Modello Model	Flangia premente Discharge flange										
	Tipo di flangia Flange type	A1	B1	A2	B2	A3	B3	C1	Ø AB	N°X	N°Y
221	140x100	146	105	182	139	216	175	112	12	1+1	2+2
251	200x140	205	146	241	182	275	216	112	12	2+2	2+2
281	224x160	229	164	265	200	299	234	112	12	2+2	2+2
311	250x180	256	183	292	219	326	253	112	12	2+2	3+3
351	280x200	288	205	332	249	368	285	125	12	2+2	3+3
401	315x224	322	229	366	273	402	309	125	12	2+2	3+3
451	355x250	361	256	405	300	441	336	125	12	2+2	3+3
501	400x280	404	288	448	332	484	368	125	12	3+3	4+4

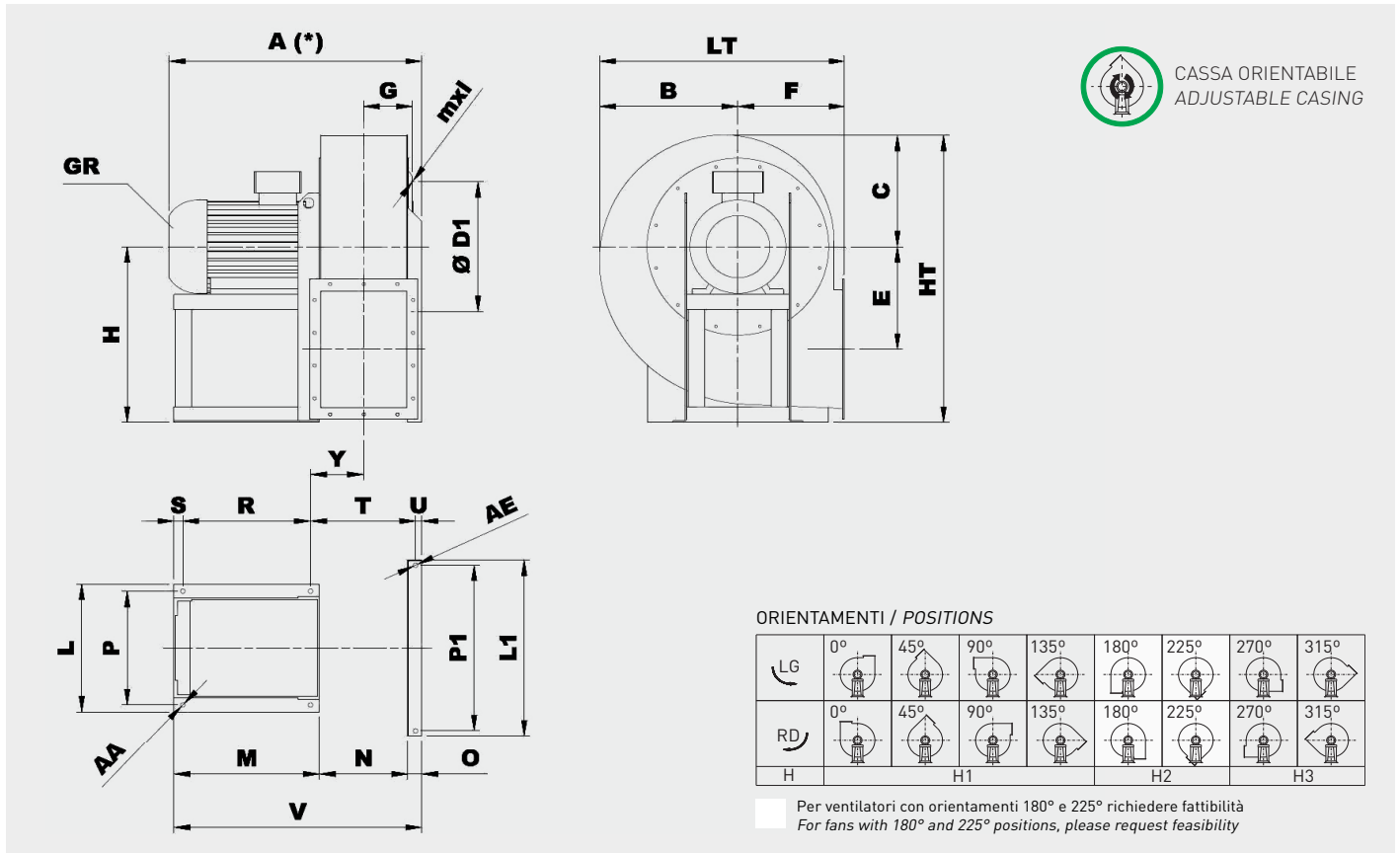
**DIMENSIONI (mm) (modelli dal 561 al 631) / DIMENSIONS (mm) (models from 561 to 631)**

Tipo Type		Ventilatore Fan											Base Base										Esecuzione 4B <sup>(1)</sup> Arrangement 4B <sup>(1)</sup>												
Ventilatore Fan	Motore GR Motor GR	A*	B	C	Ø D1	E	F	G	H			HT	LT	mx1	Y	L	P	L1	P1	M	N	O	R	S	T	U	V	Ø AA	Ø AE	A	Y	R	M	T	V
KM 561/4 R4A	132SA4	790	550	451	448	391	400	181	670	400	670	1121	950	M8X20	188	372	337	672	632	310	329	52	314	23	381	23	741	12	17	845	188	314	360	381	741
KM 562/4 R4A	112M4	750	550	451	448	391	400	181	670	400	670	1121	950	M8X20	188	324	289	672	632	310	329	52	264	23	381	23	691	12	17	795	188	264	310	381	691
KM 631/4 R4A	160M4	990	615	515	497	441	450	200	750	450	750	1265	1065	M8X20	214	440	395	762	702	470	369	52	414	28	426	23	891	14	17	1045	214	414	470	426	891
KM 632/4 R4A	132MA4	860	615	515	497	441	450	200	750	450	750	1265	1065	M8X20	209	372	337	762	702	360	369	52	314	23	421	23	781	12	17	915	209	314	360	421	781

<sup>1</sup> Con ventolina di raffreddamento / With cooling impeller  
 \* In relazione al tipo di motore / Depending on motor type

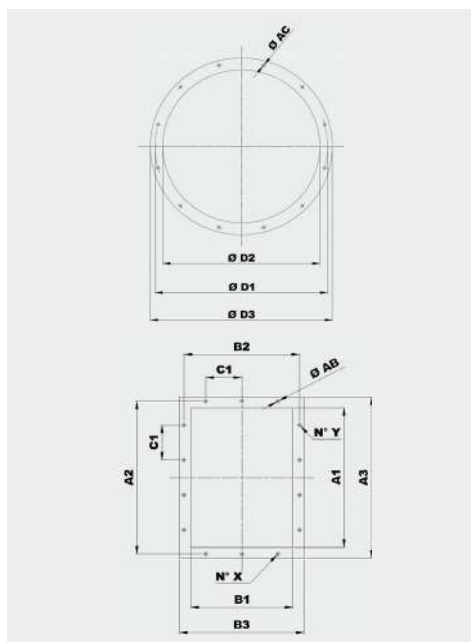

Modello Model	Flangia aspirante Inlet flange					
	Tipo di flangia Flange type	Ø D1	Ø D2	Ø D3	Ø AC	Fori Holes
561	400	448	405	485	10	12
631	450	497	455	535	10	12

Modello Model	Flangia premente Discharge flange										
	Tipo di flangia Flange type	A1	B1	A2	B2	A3	B3	C1	Ø AB	N° X	N° Y
561	450x315	453	322	497	366	533	402	125	12	3+3	4+4
631	500x355	507	361	551	405	587	441	125	12	3+3	4+4

DIMENSIONI (mm) (modelli dal 711 al 1001) / DIMENSIONS (mm) (models from 711 to 1001)

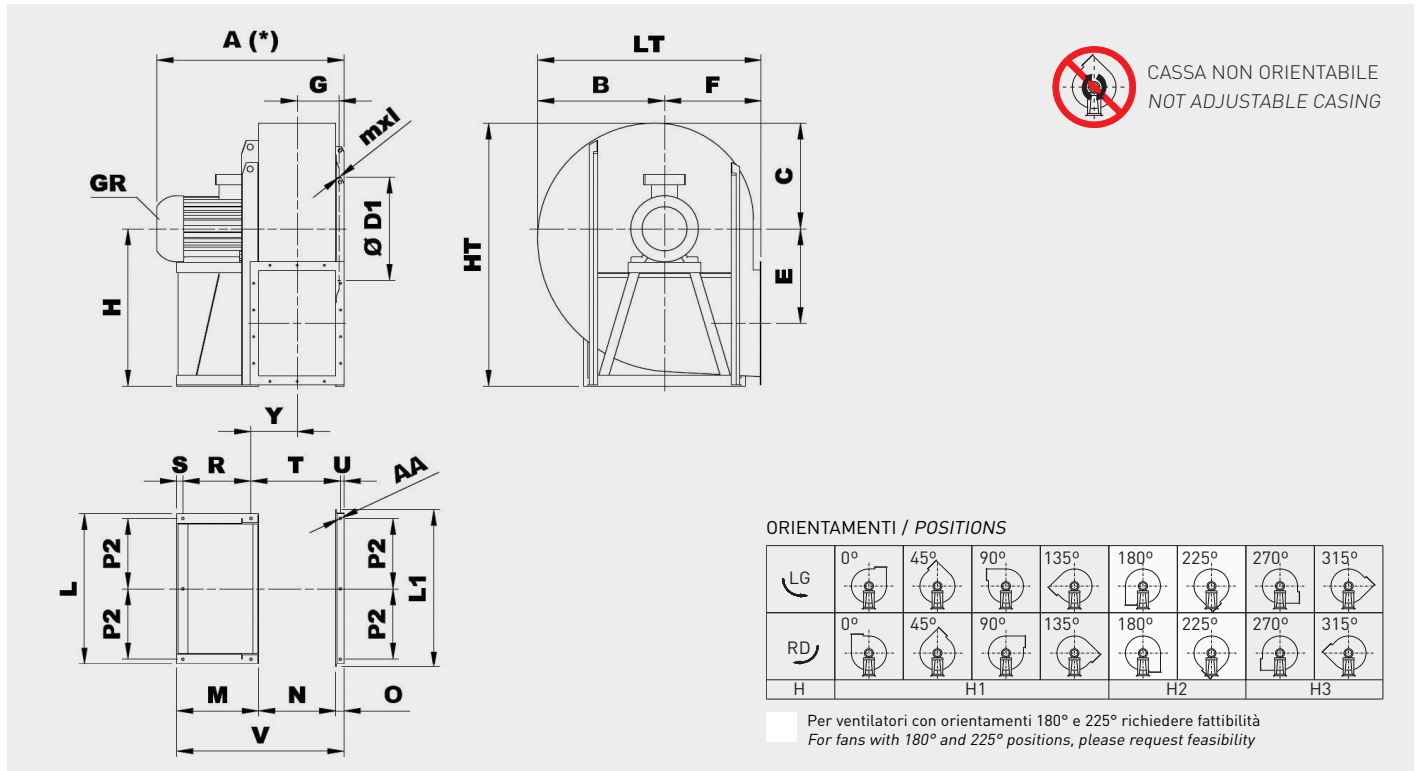

Tipo Type		Ventilatore Fan											Base Base							Esecuzione 4B <sup>(1)</sup> Arrangement 4B <sup>(1)</sup>													
Ventilatore Fan	Motore GR Motor GR	A*	B	C	Ø D1	E	F	G	H			HT	LT	mxl	Y	L	L1	M	N	O	P2	R	S	T	U	V	Ø AA	A	Y	R	M	T	V
KM 711/4 R4A	160L4	1020	690	565	551	500	500	222	670	500	850	1415	1190	M8X20	262	836	896	471	404	60	386	372	39	497	27	935	19	1020	262	372	471	497	935
KM 712/4 R4A	160M4	1020	690	565	551	500	500	222	670	500	850	1415	1190	M8X20	262	836	896	471	404	60	386	372	39	497	27	935	19	1020	262	372	471	497	935
KM 801/4 R4A	200L4	1140	770	630	629	560	560	251	750	560	950	1580	1330	M8X20	287	926	986	500	453	60	431	401	39	546	27	1013	19	1195	287	461	560	546	1073
KM 802/4 R4A	180M4	1060	770	630	629	560	560	251	750	560	950	1580	1330	M8X20	287	926	986	540	453	60	431	441	39	546	27	1053	19	1115	287	441	540	546	1053
KM 901/4 R4A	225M4	1260	860	705	698	630	630	278	850	630	1060	1765	1490	M8X20	314	1026	1086	540	507	60	481	441	39	600	27	1107	19	1315	314	523	622	600	1189
KM 902/4 R4A	225S4	1260	860	705	698	630	630	278	850	630	1060	1765	1490	M8X20	314	1026	1086	540	507	60	481	441	39	600	27	1107	19	1315	314	523	622	600	1189
KM 1001/4 R4A	280R4	1510	965	795	775	710	710	309	950	710	1180	1975	1675	M10X30	340	1128	1188	690	569	60	528	590	45	657	27	1319	19	1565	340	670	770	657	1399
KM 1002/4 R4A	250M4	1380	965	795	775	710	710	309	950	710	1180	1975	1675	M10X30	340	1128	1188	600	569	60	528	500	45	657	27	1229	19	1435	340	580	680	657	1309

<sup>1</sup> Con ventolina di raffreddamento / With cooling impeller  
\* In relazione al tipo di motore / Depending on motor type

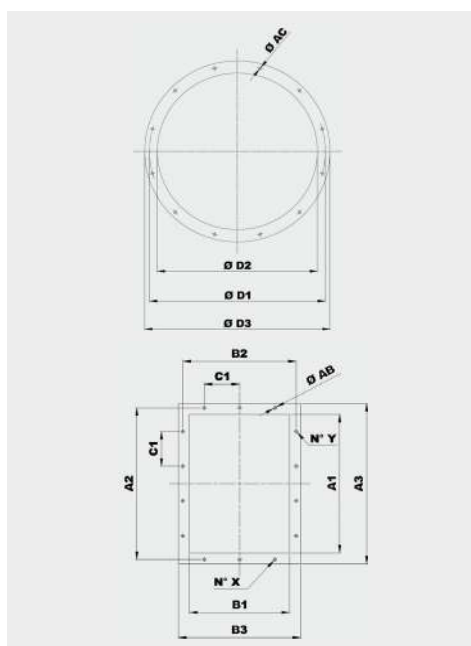

Modello Model	Flangia aspirante Inlet flange					
	Tipo di flangia Flange type	Ø D1	Ø D2	Ø D3	Ø AC	Fori Holes
711	500	551	505	585	10	12
801	560	629	566	666	10	12
901	630	698	636	736	10	12
1001	710	775	716	816	12	16

Modello Model	Flangia premente Discharge flange										
	Tipo di flangia Flange type	A1	B1	A2	B2	A3	B3	C1	Ø AB	N° X	N° Y
711	560x400	569	404	629	464	669	504	160	14	3+3	4+4
801	630x450	638	453	698	513	738	553	160	14	3+3	4+4
901	710x500	715	507	775	567	815	607	160	14	3+3	5+5
1001	800x560	801	569	871	639	921	689	200	14	3+3	4+4



**GIRANTE CON PALE RADIALI APERTE PER IL TRASPORTO PNEUMATICO - ACCOPIAMENTO DIRETTO**  
**RADIAL IMPELLER FOR MATERIAL TRANSPORT - DIRECT DRIVE**

**AMMORTIZZATORI / ANTI VIBRATION MOUNTS**

Ammortizzatori di serie / Suggested AV mounts	
Ventilatore / Fan	Esecuzione 4 / Arrangement 4
221	4 x AM 20 - 20 x 20
251/2	4 x AM 20 - 20 x 20
281/2	4 x AM 20 - 20 x 20
311/2	4 x AM 25 - 25 x 20
351/2	4 x AM 25 - 25 x 20
401/2	4 x AM 30 - 30 x 30
451/2	4 x AM 40 - 40 x 30
501/2	4 x AM 50 - 50 x 40
561/2	4 x AM 40 - 40 x 30
631/2	4 x AM 40 - 40 x 30
711/2	4 x AM 50 - 50 x 40
801/2	4 x AM 75 - 75 x 50
901/2	4 x AM 75 - 75 x 50
1001/2	6 x AM 75 - 75 x 50

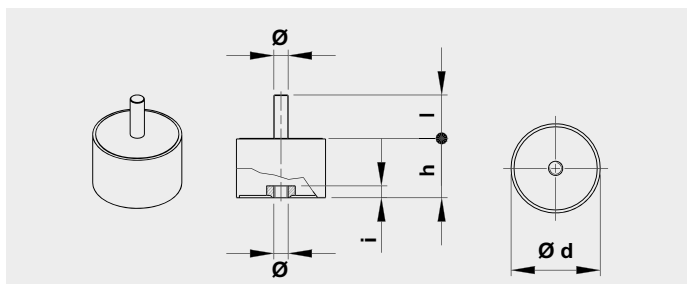

Tipo Type	Carico per 4 ammortizzatori Load for 4 AV mounts (kg)	d	h	Ø	l	Peso Weight (kg)
AM20	11÷40	20	20	M6	15	0,02
AM25	41÷80	25	20	M6	18	0,03
AM30	81÷140	30	30	M8	20	0,05
AM40	141÷224	40	30	M8	23	0,10
AM50	225÷315	50	40	M10	28	0,20
AM75	316÷630	75	50	M12	37	0,50