



# RS 125 C

RS

- Exhaust wall fan with circular inlet connection.
- Designed for mounting on external wall.
- Impeller with backward curved blades.
- The external rotor motor has maintenance-free sealed ball-bearings.
- Integrated motor protection.
- Junction box has enclosure class IP 54.
- For speed control a transformer or electronic speed controller can be connected.
- Fan housing is manufactured from galvanized sheet steel.
- Black painted for high durability.

## Accessories

- VRDE 1,5
- VRS 0,5
- VRTE C
- LDC 125

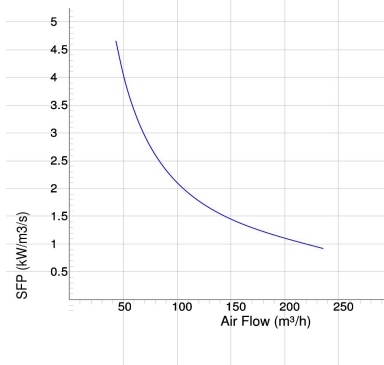
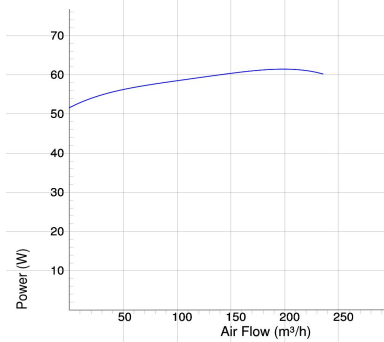
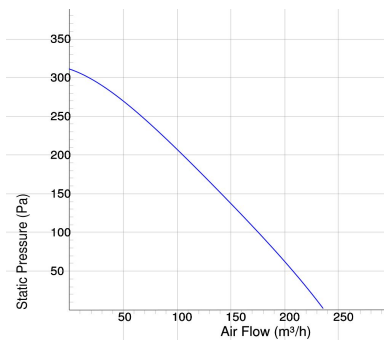

## TECHNICAL DATA

	7400002 RS 125 C man tp	7400004 RS 125 C aut tp
Voltage	230 V	230 V
Phase	1 ~	1 ~
Frequency	50 Hz	50 Hz
Power	62 W	62 W
Current	0.32 A	0.32 A
Speed	2460 r.p.m.	2460 r.p.m.
Max. temperature of transported air	60 °C	60 °C
Max. temperature of transported air when speed controlled	60 °C	60 °C
Sound pressure level at 3 m	62 dB(A)	62 dB(A)
Weight	3.4 kg	3.4 kg
Enclosure class	44 IP	44 IP
Insulation class, motor	F	F
Capacitor	2 µF	2 µF
Duct connection	125 mm	125 mm
Max. flow	238 m³/h	238 m³/h
Max. pressure	311 Pa	311 Pa
Voltage range	220-240 V	220-240 V

## SOUND DATA

	Flow (m³/h)	L <sub>wa</sub> tot dB (A)	63Hz	125Hz	250Hz	500Hz	1KHz	2KHz	4KHz	8KHz
1. Surrounding Lw dB(A) 230V	187	69	47	42	56	63	66	63	54	46
1. Inlet Lw dB(A) 230V	187	70	55	60	64	65	64	59	51	41

## DIMENSIONS

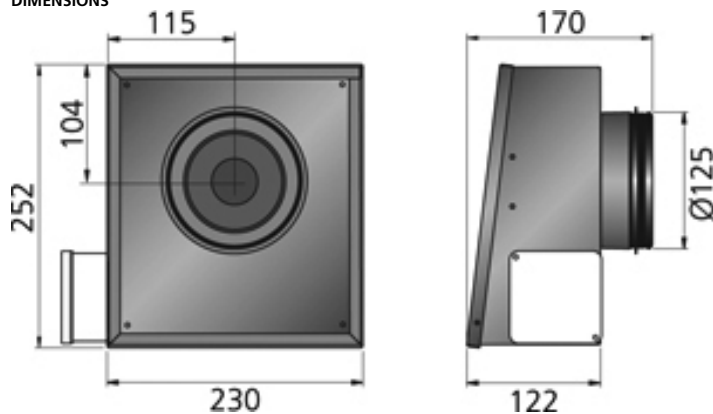

## Voltage steps

1
230V